



Written on 01 October 2017



15 minutes of reading



News

Fundamental Research

Engineering sciences

Automation and control systems

Mathematics and IT

Numerical methods and optimization

## Command and Optimization of Complex Systems



It is commonly accepted that the continuous increase in **computer**

**performance**, combined with the progress of **mathematical algorithms**, has led to unprecedented developments in the **numerical simulation of complex physical phenomena**. But these enhanced computing capabilities have also revolutionized our approach to complex systems, enabling us to optimize and command them and, ultimately, to better influence the way equipment is operated and managed.

This issue, dedicated to “**Optimization and command of complex systems**”, provides a non-exhaustive overview of such IFPEN’s research activities for applications in the field of energy: **floating offshore wind turbines, reservoir management, chemical engineering processes, the operation of engines and energy recovery.**

Lastly, let’s not forget that optimization techniques are crucial for handling the huge amounts of data derived from experimental measurements, numerical calculations and computing. This opens the way to another of IFPEN’s fundamental research themes: the optimal processing of massive data flows.

I hope you enjoy reading this issue.

**Grégoire Allaire**, Chairman of IFPEN's Scientific Board

---



[See the PDF of the letter](#)

---

# LES BRÈVES

The fatigue resistance of floating offshore wind turbines is significantly affected by the wave forces to which their supporting platforms are exposed. Passive and active damper systems — preferably inexpensive — are thus being sought to mitigate these effects.

Existing solutions such as **U-shaped column tubes**, based on the principle of the dynamic transfer of water reserves (acting as moving masses), are passive and unsuited to the changing wave direction.

To overcome these difficulties, researchers at IFPEN have come up with a **multi-directional, star-shaped damper system** that was first modeled and for which an **active control law** has been proposed<sup>(1-3)</sup>. This control is based on **the continuous management of the size of the restrictions** (fixed in the passive version) **inside the pipes, making it possible to restrict natural water flow between the reservoirs**.

The proposed system helps mitigate the **effects of the wave irrespective** of its direction. In the active version, the control law developed generates levels of performance that are much higher than those of the passive version (see figures).

There is still room for variations of this system to lead to further improvements, both in terms of platform design and control during operation. It would be possible, for example, to add and manage links between air columns or optimize the calibration for a given production site as a function of its **wind and swell characteristics**.

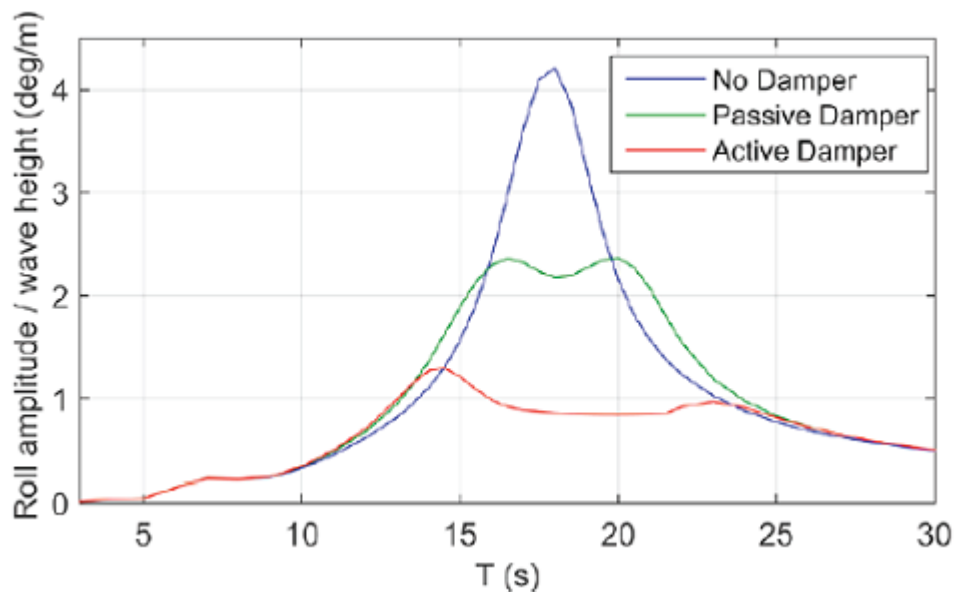

Movement control with damper systems (passive and active) for monochromatic wave agitation.

---

(1) O. Lepreux & C. Coudurier, Patent 3048409, 2017

(2) C. Coudurier, O. Lepreux, N. Petit, Proc. of 10<sup>th</sup> IFAC Conference on Manoeuvring and Control of Marine Craft, MCMC, 2015

(3) C. Coudurier, O. Lepreux, N. Petit, submitted to Journal of Ocean Engineering

---

Scientific contact: [olivier.lepreux@ifpen.fr](mailto:olivier.lepreux@ifpen.fr)

>> **ISSUE 30 OF SCIENCE@IFPEN**

The control of floating platforms for offshore wind turbines: being active reduces fatigue

**Recovering heat from exhaust gases using the Rankine thermodynamic cycle<sup>a</sup>** is one of the avenues being explored to reduce the energy consumption of IC engines.

Tried and tested for stationary applications, such as power plants, this technology becomes highly complex for transport applications due to **extremely transient operating conditions, making an efficient supervision and control system essential.**

Three application scenarios have been considered by IFPEN's teams:

- **light-duty vehicles,**
- **trucks,**
- and **diesel-electric railcars<sup>b</sup>.**

For each scenario, **the design of a pilot Rankine system required new model-based control developments:**

- **for the control of superheating at the evaporator outlet** (see figure): a new non-linear command law, enabling temperature and pressure control, was proposed;
- **for the energy supervision of the Rankine system:** a dynamic optimization approach, enabling the calculation of control setpoints as a function of operating conditions, was developed to maximize energy efficiency.

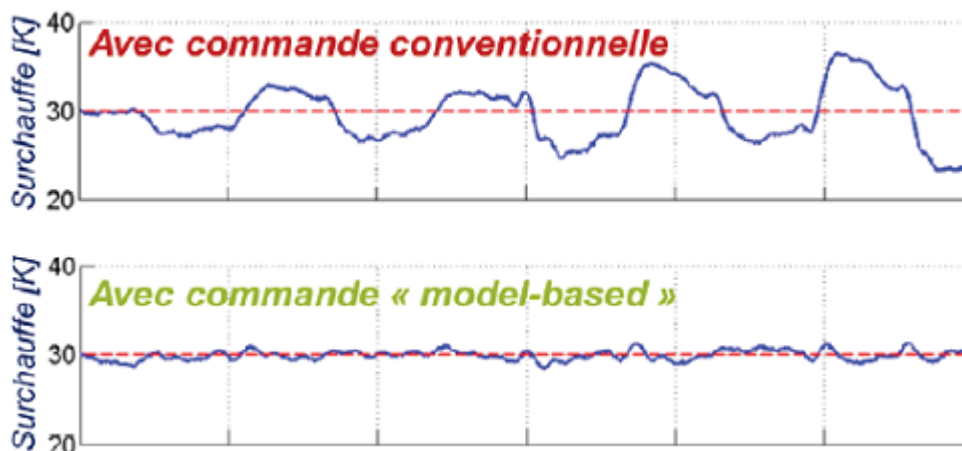

Superheating control, evaporator outlet.

Experimental validation of the system demonstrated that it could be maintained in conditions enabling continuous energy recovery, even over highly dynamic road cycles<sup>(1)</sup>. It was thus verified that **the improvement in energy saving associated with real-time dynamic optimization** was significant compared to existing technology (+ 7 %)<sup>(2)</sup>.

This pioneering work now represents a benchmark in the sector of **Rankine system control**.

---

*a- Adiabatic cycle enabling the conversion of heat into mechanical work.*

*b- The latter have been the focus of **co-development with Enogia**.*

(1) J. Peralez, M. Nadri, P. Dufour, P. Tona, [A. Sciarretta](#). **Organic Rankine Cycle for Vehicles: Control Design and Experimental Results** - IEEE Transactions on Control Systems Technology, 2017, 25(3), pp. 952 - 965.

>> DOI: [10.1109/TCST.2016.2574760](https://doi.org/10.1109/TCST.2016.2574760)

(2) J. Peralez, P. Tona, M. Nadri, P. Dufour, [A. Sciarretta](#). **Optimal control for an organic rankine cycle on board a diesel-electric railcar** - Journal of Process Control, vol. 33, 2015, pp. 1-13, ISSN 0959-1524.

>> DOI : [10.1016/j.jprocont.2015.03.009](https://doi.org/10.1016/j.jprocont.2015.03.009)

---

Scientific contact: [paolino.tona@ifpen.fr](mailto:paolino.tona@ifpen.fr)

>> **ISSUE 30 OF SCIENCE@IFPEN**

Exhaust gas heat: optimal recovery through supervision and control

**In the face of declining oil and gas reserves, increasing the productivity of oil fields has become a technological challenge of the utmost importance.** Accordingly, **well positioning and trajectory are critical factors** and industry is seeking to acquire advanced methods to optimize well placement during field development.

This development phase relies on **the simulation of fluid flows in the reservoir** to determine:

- **well position,**
- **trajectory,**
- **and type.**

Optimization consists in **maximizing an objective NPV (Net Present Value) function incorporating field production gains and drilling costs**, based on calculations derived from simulation outputs for each well (water, oil and gas production). The mixed nature of the optimization variables (continuous, integer, binary), the non-linearities of the NPV function and the associated calculation cost add considerably to the complexity of this problem.

IFPEN thus developed a two-step methodology consisting in<sup>(1, 2)</sup>:

- **determining the position and type of vertical wells** only, thereby reducing the number of variables. This makes it possible to tackle a mixed, non-linear problem (with integer and continuous variables) using a global direct search method, based on numerical simulations;
- **optimizing the trajectories of the branches** coming off **vertical wells**, using a simplified analytical model.

This sequential optimization approach enables resolution *via* adaptations of **traditional MINLP (Mixed Integer Non Linear Programming)** methods. **It can also be considered for the purposes of determining dates for bringing a well into production or closing down a well**, or the implementation of adapted strategies once a well's profitability starts to decline.

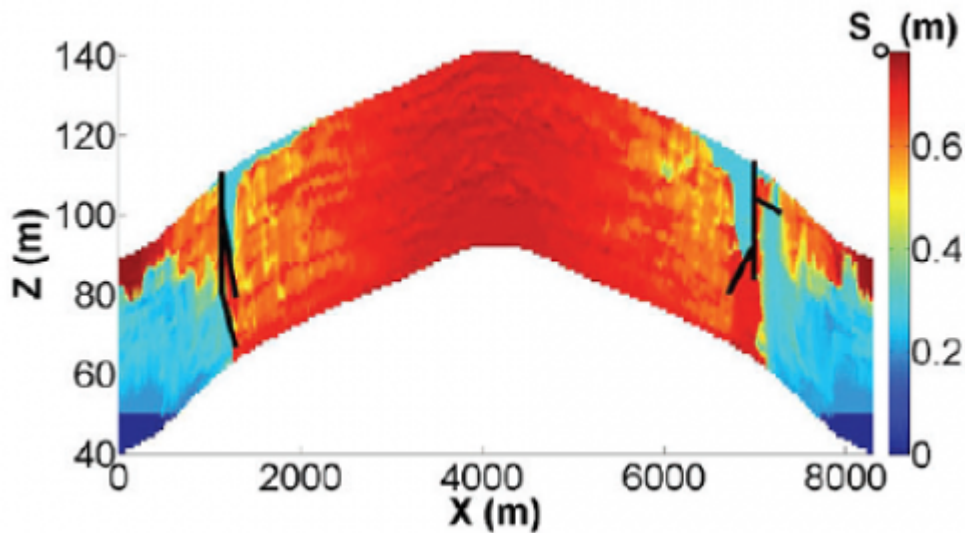

2D example of optimized trajectories for 2 producer wells (in black).

---

(1) C. Lizon, 2016, *Mixed nonlinear optimization for integer and real variables: application to well location problem in reservoir engineering*, thèse de doctorat, École polytechnique.

(2) C. Lizon, C. D'Ambrosio, M. Le Ravalec, L. Liberti, and D. Sinoquet, *A Mixed-Integer Nonlinear Optimization Approach for Well Placement and Geometry*, Proc. 14th European Conference on the Mathematics of Oil Recovery (ECMOR), 2014.

>> DOI: [10.3997/2214-4609.20141889](https://doi.org/10.3997/2214-4609.20141889)

---

Scientific contact: [Delphine Sinoquet](#)

>> [ISSUE 30 OF SCIENCE@IFPEN](#)

Optimized placements for long lasting resources



The optimized design of processes is a complex but promising approach in terms of the expected benefits for the **efficiency of industrial systems** and their **operating performance**.

It is an area that was the focus of a PhD thesis<sup>(1)</sup> conducted in partnership with the École polytechnique fédérale de Lausanne (EPFL), based on an example relating to alternative fuels: **the production of bioethanol from sugarcane and its leaves**, associated with cogeneration. The objective was to **reduce the energy consumption of the unit, while maximizing the export of surplus energy**<sup>(1-2)</sup>.

The optimization strategy consisted in considering the process as a whole, i.e. simultaneously:

- **the sequence of equipment** (reactors, exchangers, distillation columns),
- **the network of utilities** (steam and electricity),
- and **operating conditions** (temperatures, pressures, etc.).

In order to implement this strategy, it was necessary to model and simulate the entire process and the production of utilities.

A few figures illustrate the complexity of the problem:

- 28 equipment optimization variables,
- 50 material flows to be thermally integrated,
- and 75 pieces of equipment.

As a multi-objective optimization, it was possible **to generate the full range of solutions regarding economic and energy** compromise associated with one or several of the “objective” functions defined by the user.

The research demonstrated that it was possible to increase **global energy efficiency by 7%** and **electricity production by 20%**<sup>(1)</sup>, **while maintaining the same level of ethanol production**.

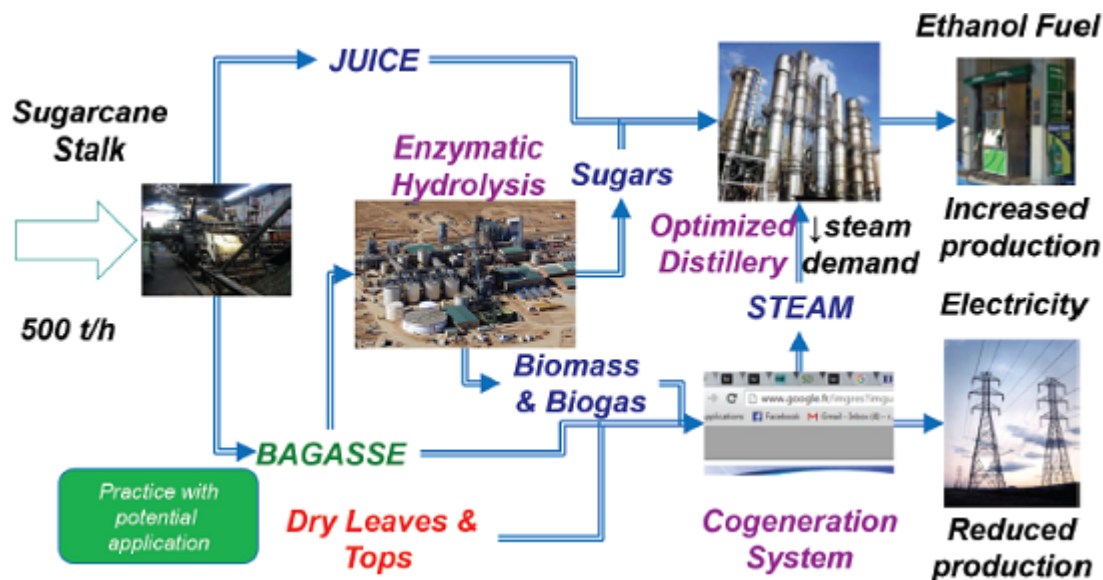

Diagram showing an ethanol production and heat/electricity cogeneration process.

- (1) R. Bechara, *Methodology for the design of optimal processes: application to sugarcane conversion processes*, thèse de doctorat, université Lyon 1 (2015)  
>> <https://tel.archives-ouvertes.fr/tel-01276302/document>
- (2) R. Bechara, A. Gomez, V. Saint-Antonin, J-M. Schweitzer, F. Maréchal, *Methodology for the optimal design of an integrated sugarcane distillery and cogeneration process for ethanol and power production* - Energy 117 (2016).  
>> DOI: [10.1016/j.energy.2016.07.018](https://doi.org/10.1016/j.energy.2016.07.018)
- (3) R. Bechara, A. Gomez, V. Saint-Antonin, J-M. Schweitzer, F. Maréchal, *Methodology for the design and comparison of optimal production configurations of first and first and second generation ethanol with power*, Applied Energy, 2016  
>> DOI: [10.1016/j.apenergy.2016.09.100](https://doi.org/10.1016/j.apenergy.2016.09.100)
- (4) R. Bechara, A. Gomez, V. Saint-Antonin, J-M. Schweitzer, F. Maréchal, *Methodology for the optimal design of an integrated first and second generation ethanol production plant combined with power cogeneration*, Bioresource Technology, 2016  
>> DOI: [10.1016/j.biortech.2016.04.130](https://doi.org/10.1016/j.biortech.2016.04.130)

Scientific contact: [adrien.gomez@ifpen.fr](mailto:adrien.gomez@ifpen.fr)

>> **ISSUE 30 OF SCIENCE@IFPEN**

Optimized design of processes: enhanced efficiency, even with ethanol

**The optimal design of mechanical structures** is hampered by the imperfect knowledge of the environmental conditions under which they will operate. The systematic incorporation of the resulting uncertainties currently relies on the intensive use of complex simulators.

Under this constraint, IFPEN is designing **wind turbine anchoring technologies and floaters** that reconcile:

- **operating robustness,**
- and **cost with a view to large-scale production.**

Since simulation based **optimization can be costly in terms of calculation time**, researchers are working on a more “**economic**” **exploration of possibilities**, particularly concerning environmental conditions. Moreover, **the relative scarcity of failures** implies that the simulated cases need to be sufficiently numerous to expect the observation of such phenomena and to adapt the design of the structure accordingly.

These two challenges were tackled respectively:

- **using dimension reduction techniques**, for **random processes modeling environmental conditions**,
- and **using accelerated Monte-Carlo simulation methods**, to reduce the number of scenarios required to estimate the probability of failure<sup>(1)</sup>.

In addition, since the optimization constraints involve the probability of failure, and the resolution method employed requires the calculation of their derivative, further work was conducted in this respect<sup>(2)</sup>.

Lastly, **still with the aim of reducing calculation times**, an alternative was applied to the **design of an offshore wind turbine anchoring solution, resistant to fatigue**: using probability constraint approximations based on the **theory of extreme values**.

Thereby, through the provision and introduction of new methodologies, but also computing equipment and algorithms, IFPEN is helping to improve design tools for floating wind turbine supports, working closely with industrial players in the sector.



Floating wind turbine

---

(1) A. Murangira, M. Munoz Zuniga, T. Perdrizet. ***Structural reliability assessment through metamodel based importance sampling with dimension reduction.***

>> <https://hal.archives-ouvertes.fr/hal-01230454/document>, 2015.

(2) W. van Ackooij, I. Aleksovska, M. Munoz Zuniga. *Submitted to Set-Valued and Variational Analysis, 2017.*

---

Scientific contact: [Miguel Munoz Zuniga](#)

>> [ISSUE 30 OF SCIENCE@IFPEN](#)

## CONTACT



[Miguel MUNOZ ZUNIGA](#)

Research engineer in uncertainty quantification and optimization  
PhD in applied mathematics

Floating wind turbine: increasing reliability in an “ocean of possibilities”

In hybrid vehicles, onboard algorithms are aimed at splitting power between the various energy sources in order to minimize fuel consumption and/or pollutant emissions. This real-time management requires a dynamic optimization approach (or optimal control).

As part of a thesis project<sup>(1, 2)</sup>, IFPEN developed an energy management optimization method incorporating the internal temperatures of the engine and/or the gas after-treatment system, – which represent dynamic states not taken into account by state-of-the-art optimized management systems<sup>a</sup>.

Initially, based on prior knowledge of the driving cycle, management laws were determined using the Pontryagin Minimum Principle<sup>b</sup>. Based on the numerical results, a compromise was established between the optimality of the management system and the complexity of the model used. For each of the different cases studied, the impact of the simplification implemented was estimated using regular perturbation theory for optimal control.

During a second phase, the ECMS method was enhanced by incorporating new thermal dynamics. This led to the development of sub-optimal strategies — not dependent on knowledge of the driving cycle, — which were then validated numerically and experimentally.

The method developed could be extended to other optimal control problems, either multi-state or, more generally, complex.

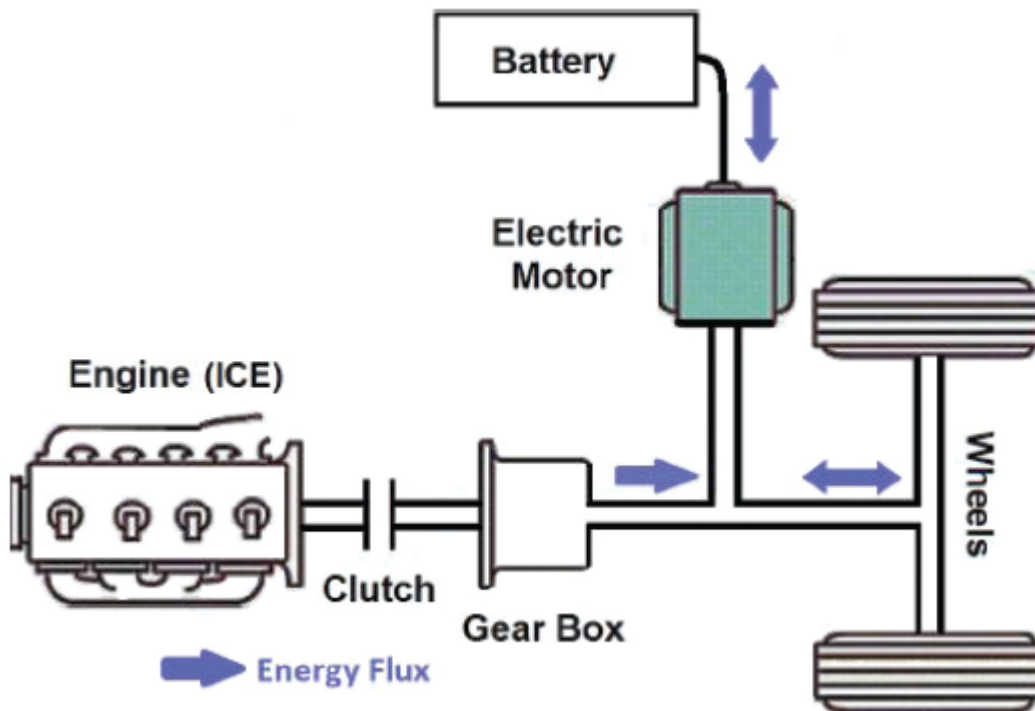

Energy flow in a hybrid vehicle, to be controlled by the onboard management system.

<sup>a</sup> based on the ECMS (Equivalent Consumption Minimization Strategy) method in which the unknown equivalent cost of electricity (adjoint state) is calculated as a function of the measured battery charge (state).

*b- mathematical principle used to specify the conditions required for optimality.*

---

(1) D. Maamria, [A. Sciarretta](#), F. Chaplais, N. Petit (2017), in Proc. of the IFAC World Congress, Toulouse, France, 9-14 Jul. 2017.

(2) D. Maamria, F. Chaplais, N. Petit, [A. Sciarretta](#) (2015), ***Comparison of several strategies for HEV energy management system including engine and catalyst temperatures*** - Proc. of the American Control Conf. (ACC), Chicago, IL, 1-3 Jul. 2015.

>> [DOI: 10.1109/ACC.2015.7171183](https://doi.org/10.1109/ACC.2015.7171183)

---

Scientific contact: [Antonio Sciarretta](#)

>> [ISSUE 30 OF SCIENCE@IFPEN](#)

Energy in vehicles: we've got it under control!

Issue 30 of Science@ifpen - Control and optimization of Complex Systems  
01 October 2017

Link to the web page :